

KALFIRE
FIREPLACES



Closed 
gas fires

DON'T COMPROMISE.



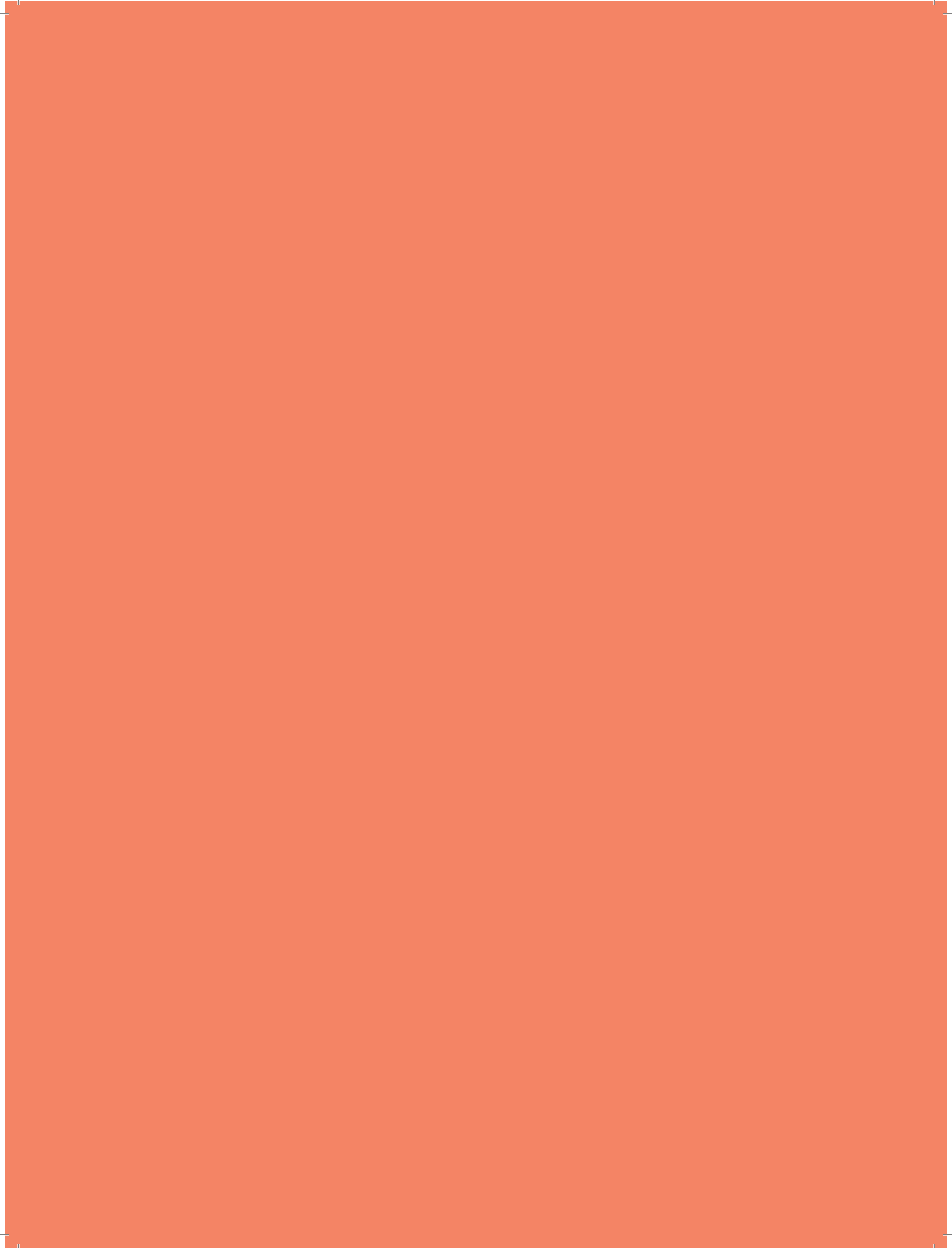

DON'T COMPROMISE.



Don't compromise

At Kalfire, we accept nothing but the best. The closed gas and wood fireplaces we develop are the result of this constant quest for perfection in design, technology and performance. We are frequently singled out for introducing innovative technology and cutting-edge style. Our patented innovations such as our air-intake system, Prestige gas burner and the Natural Spark Generator (NSG) have reinforced our reputation as a trendsetting pioneer in the fireplace sector, and we strive to retain our leading position.

We hope this product overview will inspire as well as inform you about our models. As you will see, the possibilities are limitless to create a fireplace that meets your customer's individual requirements and taste. The range of options we offer will allow you to design the fireplace that best enhances your customer's home interior, with the aid of your expertise to guide their choices. With Kalfire, neither you nor your customer ever need to compromise. We certainly don't.

Beijko van Melick
Kalfire Managing Director

DON'T COMPROMISE.

Cornerstones

Our products, our service and our business culture rest on five key values. Everything we do and everything we design is based on these five fundamental concepts, which allow us to stay ahead and retain our position as market leader.

The **experience** of something exceptional is one of the main reasons to choose a fireplace. A natural fire is a proven source of relaxation. Kalfire fireplaces are internationally reputed for their incredibly realistic play of flames.

Individuality means having the widest choice and the most design freedom possible. As a fireplace takes pride of place in a room, it needs to fit a customer's unique requirements and personal taste. Kalfire's diverse collection means there is no need to compromise.

Ease of use is a key factor in taking pleasure in something. Our fireplaces are designed to be intuitive to use, simple to maintain and easy to clean.

Durability & sustainability go without saying. Our gas and wood-burning fireplaces are equipped with innovative combustion technology that is not only durable, but environmental and economical.

Expertise is imperative for us. Our team of product designers work ceaselessly to develop innovative technology and cutting-edge performance, creating products of the highest quality. We are proud to be the market leader and all our efforts are focused on staying there.



Contents

Don't compromise - Beijko van Melick	4
Cornerstones	6
A fire that creates atmosphere, whatever the season	8
An impressively realistic play of flames	10
An optimal view of the fire	12
A gas fire personalized to your taste	14
2,000 variations of style and comfort	16
Seamless integration	18
Types of interior	20
Control at the touch of a button	22
The iMatch app	24
Ease of maintenance	26
A 40% reduction in gas consumption	28
Optimal and clean performance	30
Often imitated, never equalled	32
Burner types	34
Cornerstones: closed gas fires:	
- Individuality	35
- Experience	36
- Ease of use	36
- Durability & sustainability	37
- expertise	37
Product range	38

GAS FIRES:

Kalfire G80 series	40
Kalfire G80/48F	42
Kalfire G85/44C	44
Kalfire G90/44S	46
Kalfire G160 series	48
Kalfire G160/41F	50
Kalfire G165/37C	52
Kalfire G170/37S	54
Kalfire GP75/59F	56
Kalfire GP80/55C	58
Kalfire GP85/55S	58

Colophon

This brochure was produced by Kalfire BV.

Concept, design and editorial: DimCoppen, Tegelen

Photos: Zebra fotostudio's, Venlo

Interior furnishings: Berden Meubelen, Venlo



We reserve the right to make changes to prices and/or diagrams and to correct printing errors. The examples, photographs and values indicated are non-contractual. All prices in the price list are exclusive of VAT and shipping costs. The amended prices in this price list supersede all previous price lists. Optional mounting trims are delivered separately from the fireplace.





A fire that creates atmosphere, whatever the season

A burning fire in a fireplace typically evokes a cold winter's day. Traditionally, fireplaces have been viewed mainly as a source of heat, but today their use is more commonly to create a convivial atmosphere in an interior. Kalfire closed gas fires are often used principally in this way. There is nothing more soothing than a softly crackling fire burning in the hearth, and nothing more relaxing than gazing into the flames. The presence of a fireplace or a contemporary gas fire makes a space more convivial, even in the summer.

The size or style of a room is not an obstacle – our closed gas fires are suitable for any type of interior. We design our models with perfection in mind and never compromise on quality or style.

EXPERIENCE



An impressively
realistic play
of flames

Prestige burner



Choose your fire

What would work better in your living space, a high blazing fire or a long bed of flames? Kalfire has developed innovative burners adapted to either situation.

Prestige burner (Kalfire GP-range)

The patented Prestige burner is integrated directly within highly realistic ceramic logs, which are stacked in a pyramid. This results in high, blazing flames that leap directly from the logs, giving an unparalleled impression of a wood fire.

3D burner (Kalfire G-range)

Like the Prestige burner, this innovation was designed and developed by Kalfire. It allows an elongated, horizontal fireplace (up to 170 cm in width) that suits contemporary interiors perfectly. A closed gas fireplace equipped with a 3D burner produces flames that are virtually indistinguishable from those of a wood fire. Fireplaces with a 3D burner are supplied with a ceramic log set as standard, but it is also possible to choose an exclusive log set or a bed of white, beige or grey stones or cryptonite.

3D burner



EXPERIENCE





KALFIRE GP105/79F with brick-effect interior

An optimal view of the fire



Kalfire's closed gas fires stand out for their clean, streamlined design, free of a distracting metal frame around the glass. This offers a clear view of the fire from all angles.

EXPERIENCE





A gas fire personalized to your taste

A gas fire is an important feature of your living area. It is both an object of design as well as a creator of atmosphere – particularly if it is able to realistically create the illusion of an open wood fire. Have you just bought a new home or perhaps are renovating your current home? Is an architect helping you design or choose a gas fire or do you have your own ideas? Kalfire offers lots of options to personalize each gas fire to your taste.

INDIVIDUALITY





2,000 variations of style and comfort



Front model - KALFIRE G60/48F



Corner model - KALFIRE G105/37C



3-sided model - KALFIRE G90/44S



Room divider - KALFIRE GP85/50R

We offer a wide selection of latest-generation closed gas fire models in a range of sizes. In all, no less than 2,000 variations of these models can be created. And thanks to our focus on innovation, the number of possibilities we provide is continually increasing.

The first decision is to choose the basic format of your gas fire: a front-facing model, a corner model, a three-sided model, or a double-sided tunnel or room-dividing model. From there, we offer a wide range of options that allow you to give a personal touch to your choice. Based on your taste and specific preferences, a Kalfire distributor can explain the type of burner (3D or Prestige burner) in the different models, and the various options you can choose for the frame, the rear panel, the hearth furnishings, and more. In this way, step by step you can design a unique fire that corresponds exactly to your wishes.

INDIVIDUALITY





KALFIRE GP110/75C

Seamless integration



Our closed gas fires blend in perfectly in any interior and offer an optimal view of the flames. The hearth that extends from the fire, often in stone, extends all the way to the frameless glass panel. The interior side panels extend seamlessly to the wall surrounding the fire. You can also opt for a rear panel that extends outside of the fire. In this case, no metallic frame is visible. This results in a fire with clean, minimalist lines that blends seamlessly into the surroundings, enhancing the impression of an open fireplace.

INDIVIDUALITY



Types of interior



Brick effect: rear panel, hearth step and vertical passepartouts (GP105/79F, GP75/59F)



Boom brickwork effect: rear panel, hearth step and vertical passepartouts (GP75/59F)



Clay (GP60/79F)



Flat (1 piece) (front model, tunnel model, room divider)



Flat (3-sections) (corner model, 3-sided model)



Black ceramic glass



Design (ridged surface)

The interior of a fireplace is a key element of its style, impacting its appearance even when it is not in use. As a backdrop to the fire, it can provide contrast or even reflect and amplify the play of flames. Kalfire closed gas fires offer a choice of three different types of interior: the standard is a minimalist interior with a flat surface; alternatively, as an option you can choose black ceramic glass or a ridged design.

Besides these three standard interiors, several special interiors are available for specific products:

- Brick effect: rear panel, hearth step and vertical passepartouts (GP105/79F, GP75/59F)
- Boom brickwork effect: rear panel, hearth step and vertical passepartouts (GP75/59F)
- Clay (GP60/79F)

INDIVIDUALITY



Control at the touch of a button

KALFIRE GP70/75S with NSG

The **iMatch remote control** supplied as standard with every model allows you to control your gas fire with ease. At the touch of a button you can turn the fire on or off or adjust the flame height. There are eight standard settings, plus a special ECO setting; this energy-saving setting automatically makes the flame level fluctuate, which considerably reduces gas consumption.



EASE OF USE



The iMatch app

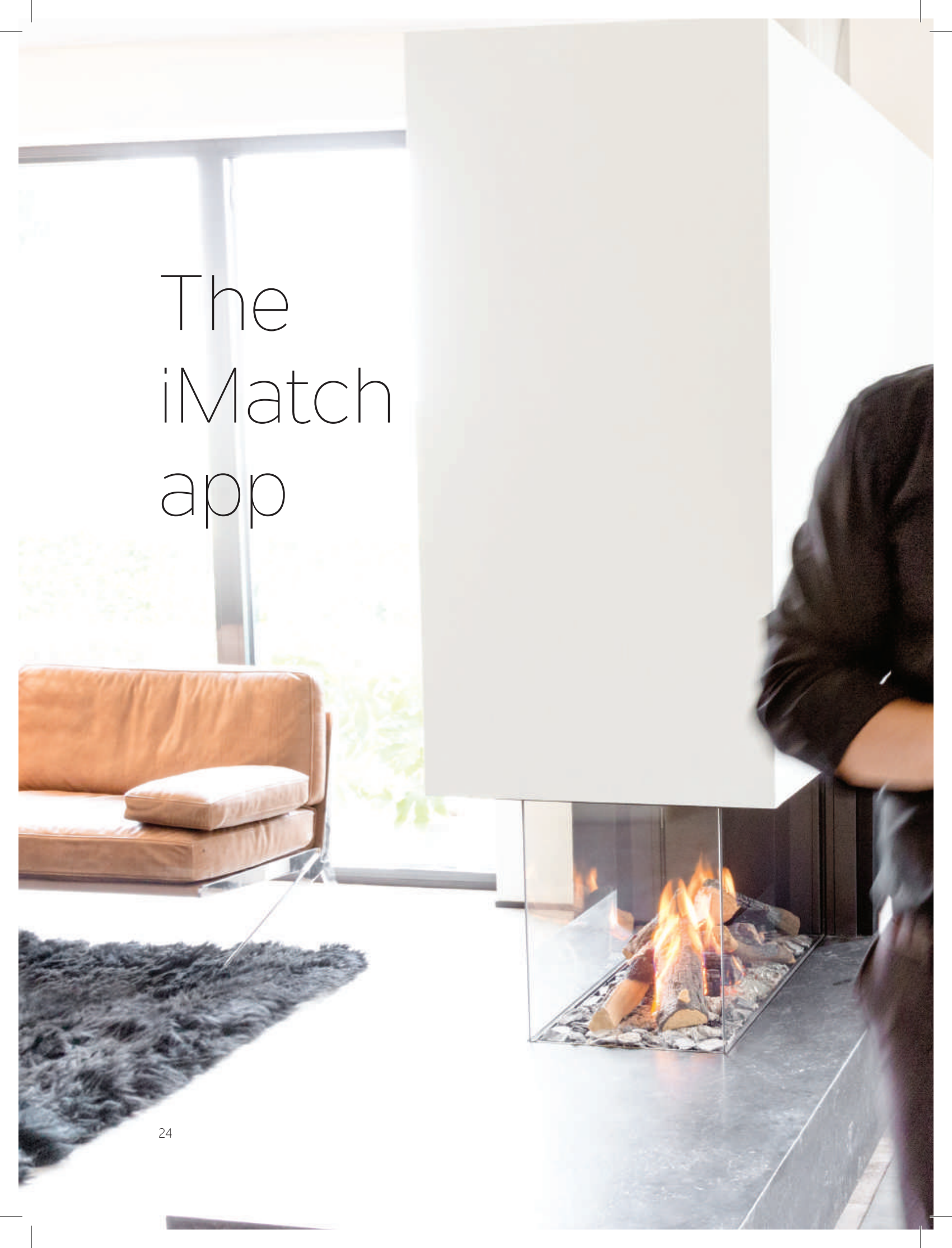



Our gas fires also have the option of including a receiver that works in tandem with a special Kalfire application that can be downloaded free from online Apple or Google (Android) app stores. This allows you to control your gas fire from your **smartphone or tablet**. If your home has a home automation (domotics) system, control of your gas fire can be integrated in this.

EASE OF USE





Easy Door System



To make cleaning your gas fire as simple as possible, our models feature the **Easy Door System**. Cleaning the glass of a fire has never been so easy. This unique system allows the glass panel to be removed in four simple steps. No special tools are required. After cleaning, the door can be replaced just as easily.

EASE OF USE





A 40%
reduction
in gas
consumption

For years, Kalfire has been a benchmark in sustainable energy by virtue of its fires' low energy consumption. The ECO setting is a prime example. In addition to the eight standard flame height settings, our fires include a ninth, energy-saving option. When the ECO setting is selected on the iMatch remote control or the iMatch app, an electronically operated valve alternately increases and reduces the gas supply to the fire following a sine wave pattern. This creates the appearance of naturally fluctuating flames as in a wood-burning fire.

This continuous variation in flame play is not only aesthetic, it also significantly decreases the amount of gas consumed – a reduction of up to 40% compared to the highest setting. Our closed gas fires are not just renowned for their contemporary style; they have exceptional performance, complying with the most recent and demanding standards. Kalfire technology gives you the guarantee of a gas fire that is environmentally sustainable, durable and economical.

DURABILITY & SUSTAINABILITY





WÖHLER A 400

Luftgas		30.02.2017		03.00h 00min	
O ₂ :	20.8%	T ₁ :	49.6 °C	✓	
CO ₂ :	0.1%	T ₂ :	81.1 °C		
Q _W :	---	η _W :	---	-Po	
CO _W :	---	θ ppm	P ₁ :	---	
CO _W :	---	ppm	λ :	---	
T ₁₂ :	---	C	m _W :	---	
			Stop		

ESC ↑ ↓ ⏻

Optimal and clean performance



During the periodic maintenance visits for your Kalfire gas fire, the installer will check that the flue is functioning correctly and that the combustion of your fire is optimal. During this check, the installer can benefit from the patented measuring points integrated in all our gas fires. These measuring points enable the concentrations of O₂ (fresh air) and CO (smoke) to be easily read. The first value provides information on how the flue is functioning and the second on the quality of combustion. Any malfunctions in the flue can thus be quickly detected, ensuring that the gas fire continues to operate optimally and resulting in environmentally sound performance for many years.



Often imitated, never equalled

Kalfire gas fires are designed and made by our own teams. Our R&D department uses a process of continuous innovation, rapidly developing new ideas and bringing them to market after thorough testing. Many of our groundbreaking innovations have been imitated, but they have never been equalled. It is not by chance that we hold a diverse range of patents for cutting-edge technology such as the Prestige burner and the Natural Spark Generator (NSG).

The colour, glow and height of the flames of our gas fires make them virtually impossible to distinguish from those of a wood-burning fire. This achievement is due to the ceaseless work of our R&D team, which has succeeded in creating such a realistic play of flames through its unerring attention to detail. We design the best closed gas fires on the market – with no compromise.



Kalfire distributors share our passion

Our gas fires are available exclusively from our network of distributors, who have been selected with the utmost care. Meticulously trained by Kalfire, they know every aspect of our products down to the smallest detail and share our passion and expertise.

Only a certified Kalfire distributor can install our built-in fires correctly and safely. This will ensure that the fire performs optimally and respects all warranty and safety requirements. Your Kalfire distributor can also help you create the gas fire that meets all your requirements and bears the mark of your individual style. This is our guarantee.



EXPERTISE



Burner types



GP-SERIES



The patented Prestige burner is incorporated into the full length of the ceramic logs, producing flames that seem to come directly from the logs. The intelligent distribution of gas flow creates low-capacity, naturally undulating flames.



KalGlow glowing fibres incorporated in the logs create an even more naturalistic effect.



The hand-painted ceramic logs are virtually indistinguishable from wood from any angle.

G-SERIES

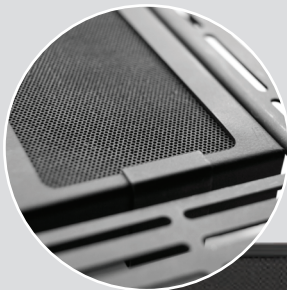

A 10-cm perforated burner plate creates a 3D flame pattern that gives depth to the fire and intelligently distributes the gas flow to result in higher flames at low capacity.



KalGlow fibres create a realistic, warm, glowing effect at any flame setting.

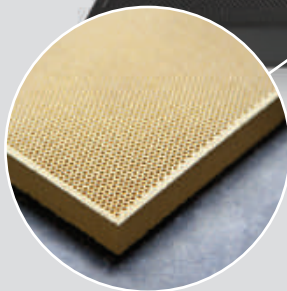

As the ceramic heats up, the heat is reflected, promoting optimal combustion and vivid flames.

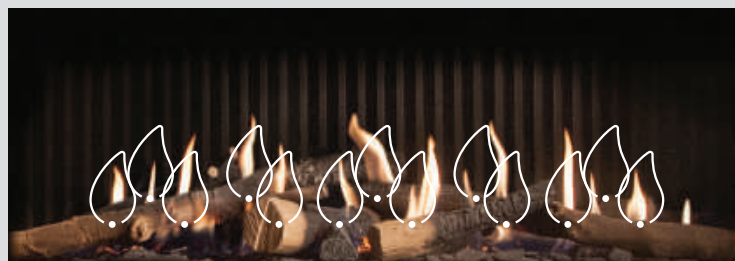

Cornerstones: closed gas fires

INDIVIDUALITY



Interior

Kalfire's closed gas fireplaces are available with three different interiors:

- Flat (one piece or in three sections)
- Black ceramic glass
- Design



Flat (1 piece) (front model, tunnel model, room divider)



Flat (3-sections) (corner model, 3-sided model)



Black ceramic glass

Besides these three standard interiors, several special interiors are available for specific products:

- Brick effect: rear panel, hearth step and vertical passepartouts (GP105/79F, GP75/59F)
- Boom brickwork effect: rear panel, hearth step and vertical passepartouts (GP75/59F)
- Clay (GP60/79F)



Design



Brick effect: rear panel, hearth step and vertical passepartouts (GP105/79F, GP75/59F)



Boom brickwork effect: rear panel, hearth step and vertical passepartouts (GP75/59F)



Clay (GP60/79F)

Filling

The G models come either with a standard ceramic log set, exclusive log set, white stones, grey stones or black cryptonite stones. The GP models are equipped with a standard ceramic log set.



White stones

Gray stones

Cryptonite stones



Ceramic log set (standard)



Exclusive ceramic log set

Mounting trims

All front, double-sided (tunnel) and room divider models have a standard mounting trim of 3 cm and optional trims of 7 cm or 10 cm. The bottom frame can be reduced in size or removed completely. Optional mounting trims can also be chosen for the room dividers, GP80/55C and GP85/55S.

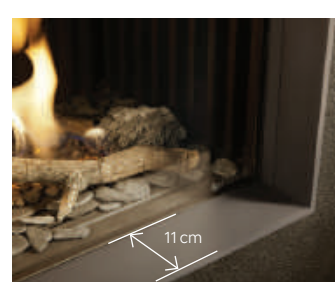

4-sided: frame depth 3 cm, trim 4 mm 4-sided: frame depth 7 cm, trim 8 mm 4-sided: frame depth 10 cm, trim 8 mm
(As the frame extends inside the hearth, its total depth including the part visible inside the glass panel is 7 cm, 11 cm or 14 cm.)



Hybrid / LED function

Gas fires with a Prestige burner can be equipped with a hybrid function that uses Philips Lumileds variable LED lights in the fire bed to create a realistic effect of a glowing bed of embers. This can be activated even in warmer weather, making the hearth an attractive feature year round.



Natural Spark Generator

The Natural Spark Generator (NSG) creates small sparks that escape from the flames and burn out slowly, resulting in an amazingly realistic simulation of a wood fire. This is available as an option with Prestige burners.



Non-reflective glass

All front models can be fitted with non-reflective glass, reducing reflection to less than 1% and further creating the experience of an open fire.



Seamless integration

The interior of the fireplace can extend to the hearth or outside the fire without a visible trim, resulting in a seamless, sleek design that blends in perfectly in any interior.

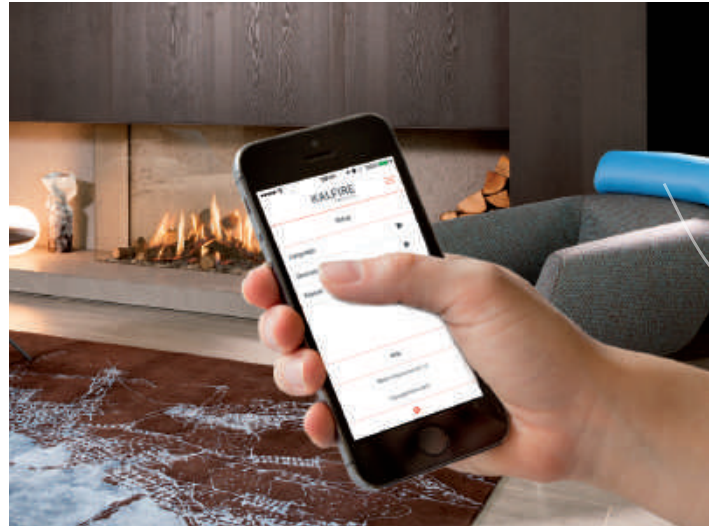

iMatch

All gas fireplaces are supplied with an iMatch remote control as standard, allowing the fire to be controlled at a touch. There is also the option of including a receiver that works in tandem with a special Kalfire app to control the gas fire from a smartphone or tablet. The gas fire can also be integrated in a home automation system.



Easy Door system

The Easy Door system enables the glass to be cleaned easily, without the need for any special tools (the glass pane can be removed simply in just ten seconds).



A 40% reduction in gas consumption

The ECO setting is an energy-saving option that works by electronically controlling a gas valve that alternately increases and reduces the gas supply to the fire following a sine wave pattern. This reduces gas consumption by up to 40% compared to the highest setting, while creating the appearance of the naturally fluctuating flames of a wood-burning fire.

All Kalfire closed gas fires comply with eco-design standards and are suitable for well-insulated buildings with low heating demands.

Optimal and clean performance

During periodic maintenance visits, the installer can check that the flue is functioning correctly and that the combustion of the fire is optimal using the patented measuring points integrated in all our gas fires. These measuring points enable the concentrations of O₂ (fresh air) and CO (smoke) to be easily read.



Technical unit

The technical unit can be easily accessed to carry out routine maintenance. It can be placed up to 4 metres away from the fire's gas connection. The technical unit is connected with flexible gas hose of 1.5 meter (standard, 4 meter is optional) at the left side of the fireplace.

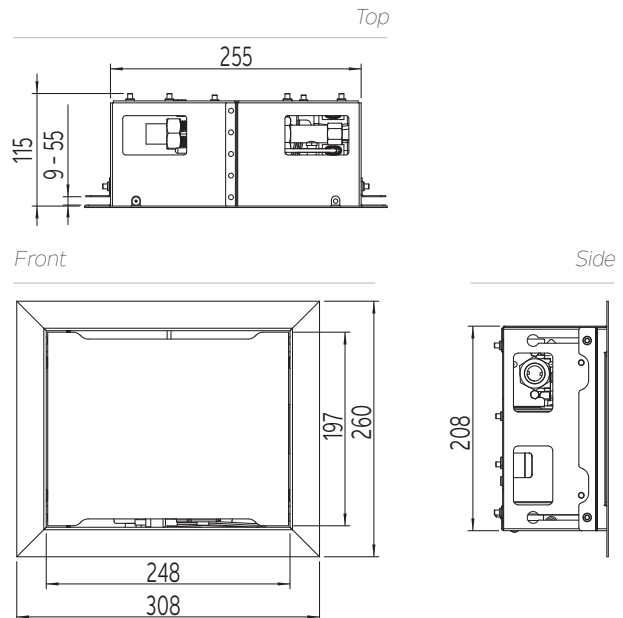

Convection casing

The convection casing ensures that the warm air generated by the fireplace is distributed evenly around the room, keeping the indoor temperature at a comfortable level. The improved, quicker heat distribution means that more or alternative finishing materials can be used for the interior.

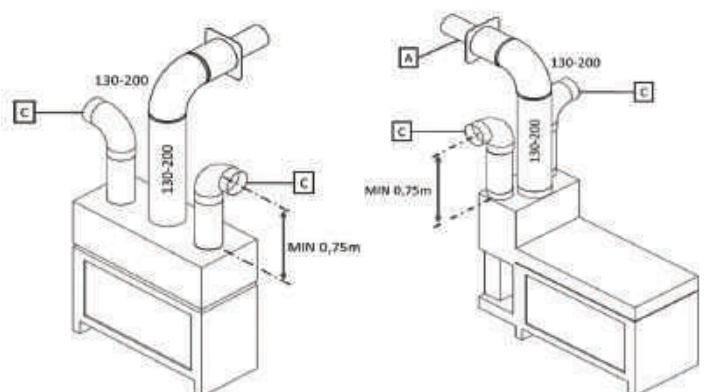

Product range



Front model



Corner model



3-sided model



Tunnel model



Room divider model



Glass sizes: gas fires with Prestige burner (GP range)

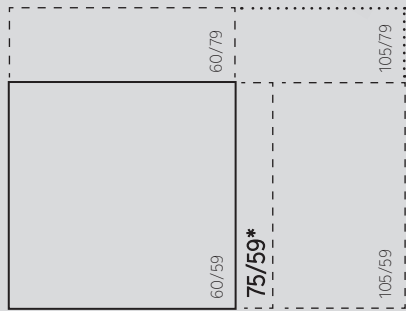

Glass sizes: gas fires with 3D burner (G range)

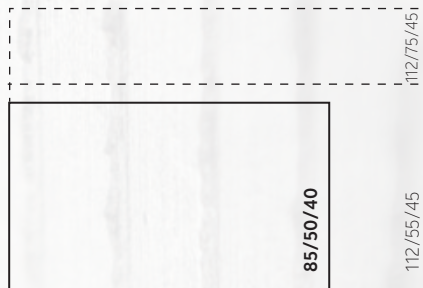
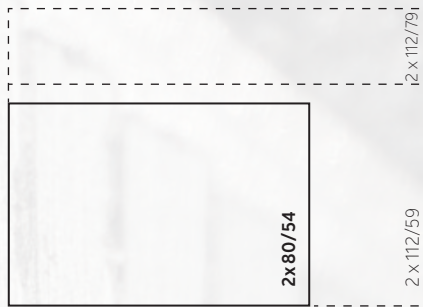
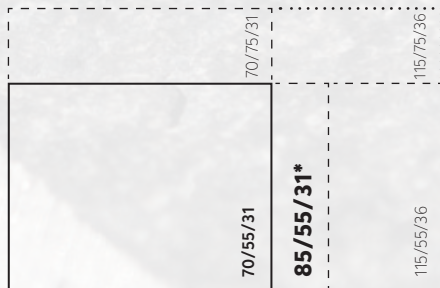
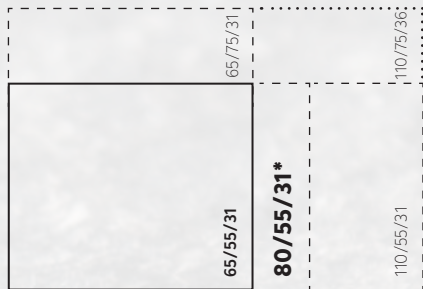
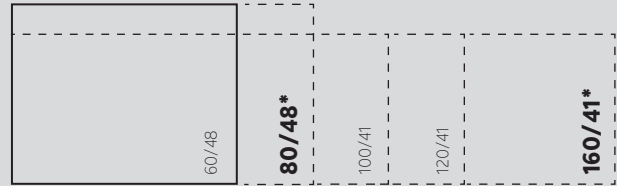

Width x Height (x Width Side glass)

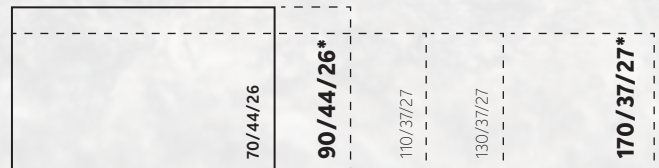
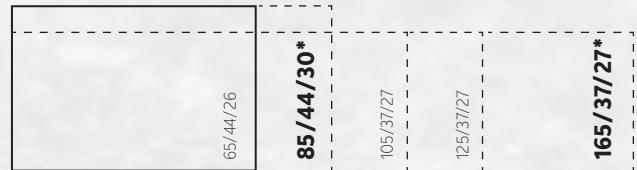

Width x Height (x Width Side glass)

* Available in/coming soon to Australia

PRODUCT RANGE



Kalfire G80 AU - series



Technical information

Kalfire G80/48F AU

Heat output (natural gas)

7,9 kW

Energy Efficiency

6 Star

Max Energy Input (natural gas)

29.2 MJ/hr

Approx appliance size (mm)

976w x 1035-1365h x 470d

Approx viewable front glass (mm)

800w x 480h

Flue connection

Ø130/200

Model

front

Burner type

Kalfire 3D burner

Suitable for

Natural gas,
Propane/NZLPG/ULPG (optional)

Features

- detachable mesh guard
- 3 cm mounting trim
- interior: black ceramic glass
- filling: exclusive ceramic logs, cryptonite (optional)
- anti-reflective glass

Kalfire G85/44C AU

Heat output (natural gas)

7,9 kW

Energy Efficiency

6 Star

Max Energy Input (natural gas)

29.2 MJ/hr

Approx appliance size (mm)

1016w x 1035-1365h x 470d

Approx viewable front glass (mm)

856w x 440h

Approx viewable side glass (mm)

354w x 440h

Flue connection

Ø130/200

Model

corner left / corner right

Burner type

Kalfire 3D burner

Suitable for

Natural gas,
Propane/NZLPG/ULPG (optional)

Features

- detachable mesh guard
- 3 cm mounting trim
- interior: black ceramic glass
- filling: exclusive ceramic logs, cryptonite (optional)

Kalfire G90/44S AU

Heat output (natural gas)

7,9 kW

Energy Efficiency

6 Star

Max Energy Input (natural gas)

29.2 MJ/hr

Approx appliance size (mm)

1056w x 1053-1413h x 470d

Approx viewable front glass (mm)

900w x 440h

Approx viewable side glass (mm)

354w x 440h

Flue connection

Ø130/200

Model

3-sided

Burner type

Kalfire 3D burner

Suitable for

Natural gas,
Propane/NZLPG/ULPG (optional)

Features

- detachable mesh guard
- 3 cm mounting trim
- interior: black ceramic glass
- filling: exclusive ceramic logs, cryptonite (optional)

Dimensional drawing Kalfire G80/48F AU

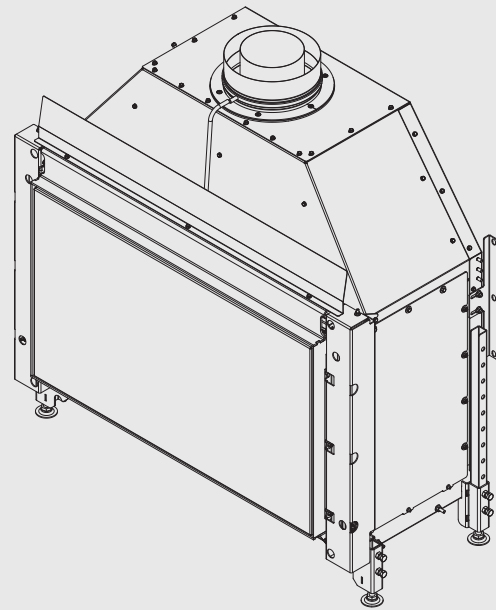
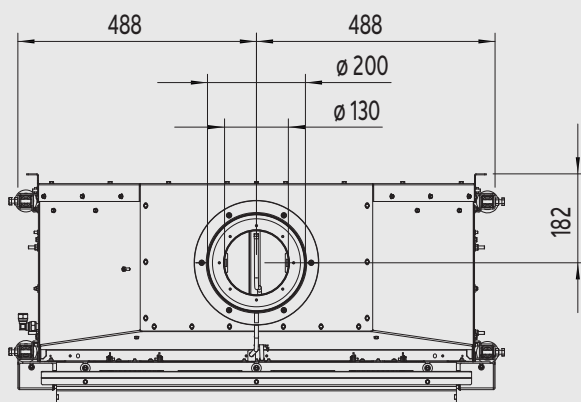
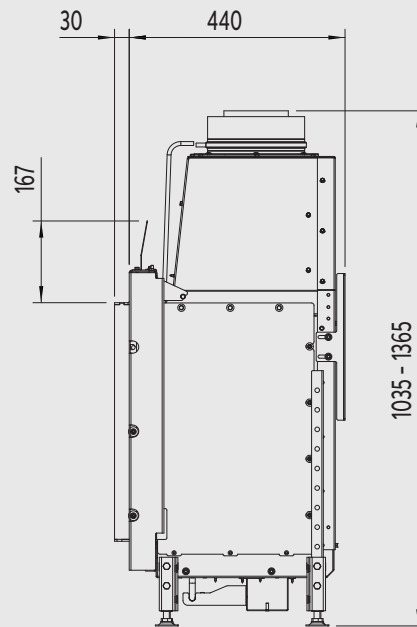
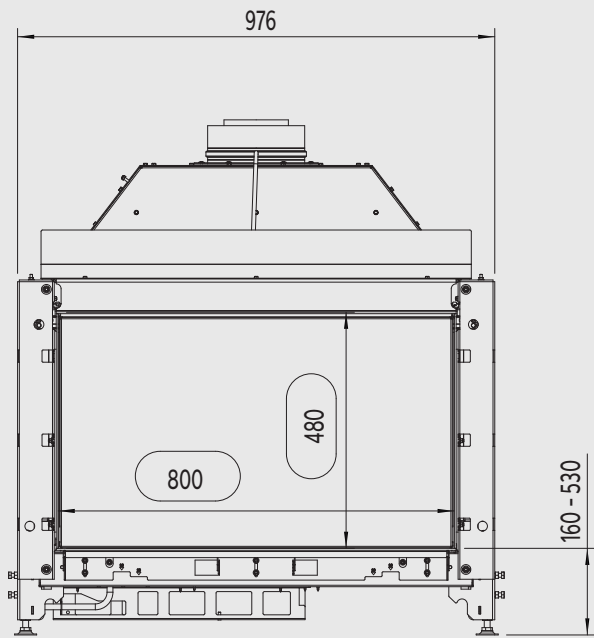



KALFIRE G80/48F



Kalfire G80/48F AU

Glass size:

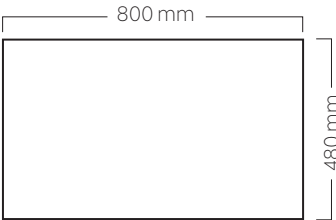

Natural gas



Propane
NZLPG/ULPG

PRODUCT RANGE





KALFIRE G85/44C



Kalfire G85/44C AU

Glass size:

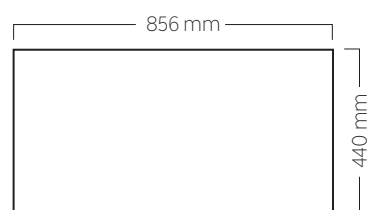

Natural gas



Propane
NZLPG/ULPG

PRODUCT RANGE





KALFIRE G90/44S



Kalfire G90/44S AU

Glass size:

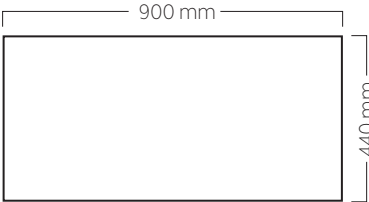

Natural gas



Propane
NZLPG/ULPG

PRODUCT RANGE



Kalfire G160 AU - series



Technical information

Kalfire G160/41F AU

Heat output (natural gas)

12,7 kW

Energy Efficiency

6 Star

Max Energy Input (natural gas)

47.2 MJ/hr

Approx appliance size (mm)

1776w x 955-1350h x 430d

Approx viewable front glass (mm)

1600w x 410h

Flue connection

Ø130/200

Model

front

Burner type

Kalfire 3D burner

Suitable for

Natural gas,
Propane/NZLPG/ULPG (optional)

Features

- detachable mesh guard
- 3 cm mounting trim
- interior: black ceramic glass
- filling: exclusive ceramic logs, cryptonite (optional)
- anti-reflective glass

Kalfire G165/37C AU

Heat output (natural gas)

12,7 kW

Energy Efficiency

6 Star

Max Energy Input (natural gas)

47.2 MJ/hr

Approx appliance size (mm)

1816w x 955-1350h x 430d

Approx viewable front glass (mm)

1650w x 370h

Approx viewable side glass (mm)

264w x 370h

Flue connection

Ø130/200

Model

corner left / corner right

Burner type

Kalfire 3D burner

Suitable for

Natural gas,
Propane/NZLPG/ULPG (optional)

Features

- detachable mesh guard
- 3 cm mounting trim
- interior: black ceramic glass
- filling: exclusive ceramic logs, cryptonite (optional)

Kalfire G170/37S AU

Heat output (natural gas)

12,7 kW

Energy Efficiency

6 Star

Max Energy Input (natural gas)

47.2 MJ/hr

Approx appliance size (mm)

1856w x 955-1350h x 430d

Approx viewable front glass (mm)

1700w x 370h

Approx viewable side glass (mm)

264w x 370h

Flue connection

Ø130/200

Model

3-sided

Burner type

Kalfire 3D burner

Suitable for

Natural gas,
Propane/NZLPG/ULPG (optional)

Features

- detachable mesh guard
- 3 cm mounting trim
- interior: black ceramic glass
- filling: exclusive ceramic logs, cryptonite (optional)

Dimensional drawing Kalfire G160/41F AU

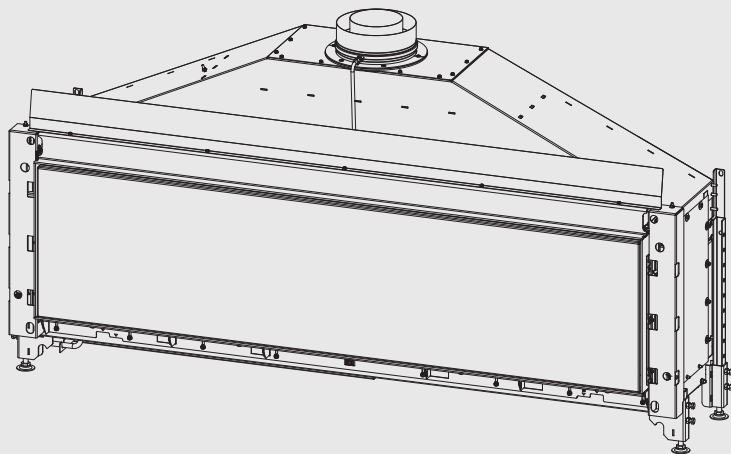
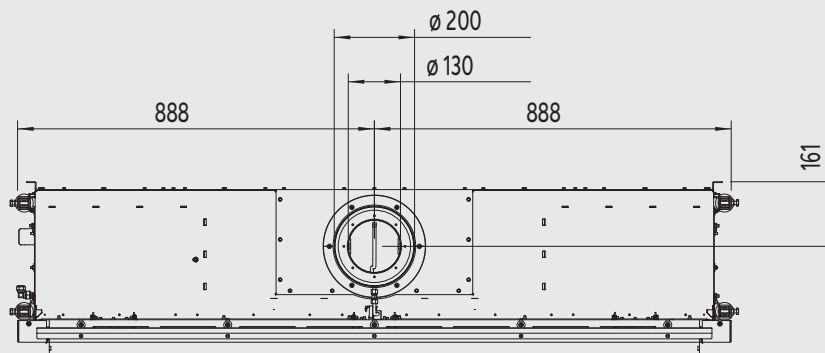
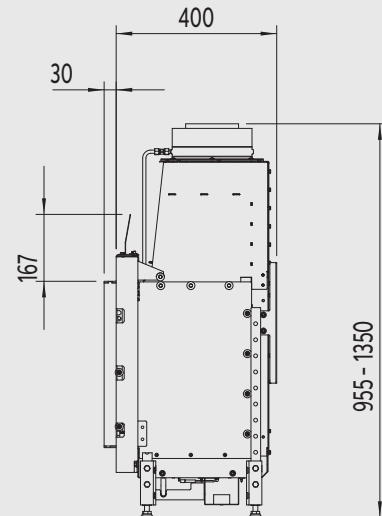
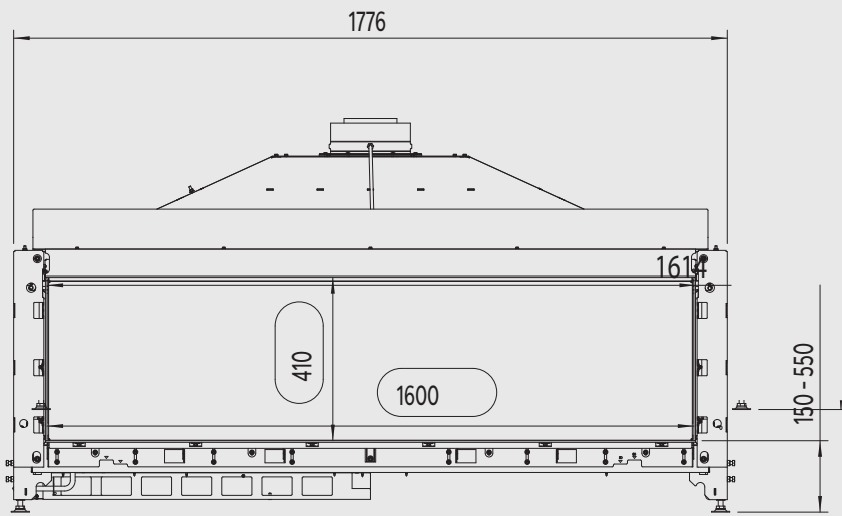



KALFIRE G160/41F

Kalfire G160/41F AU



Glass size:

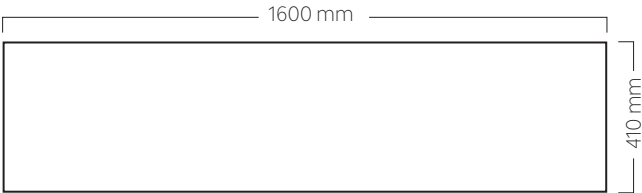

Natural gas



Propane
NZLPG/ULPG

PRODUCT RANGE





KALFIRE G165/37C

Kalfire G165/37C AU



Glass size:

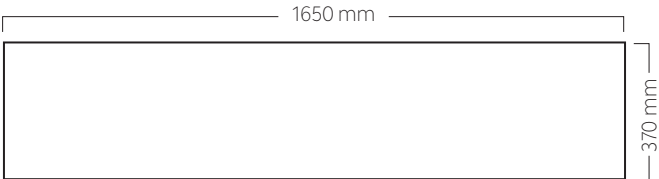

Natural gas



Propane
NZLPG/ULPG

PRODUCT RANGE





KALFIRE G170/37S



Kalfire G170/37S AU

Glass size:



Natural gas



Propane
NZLPG/ULPG

PRODUCT RANGE





KALFIRE GP75/59F

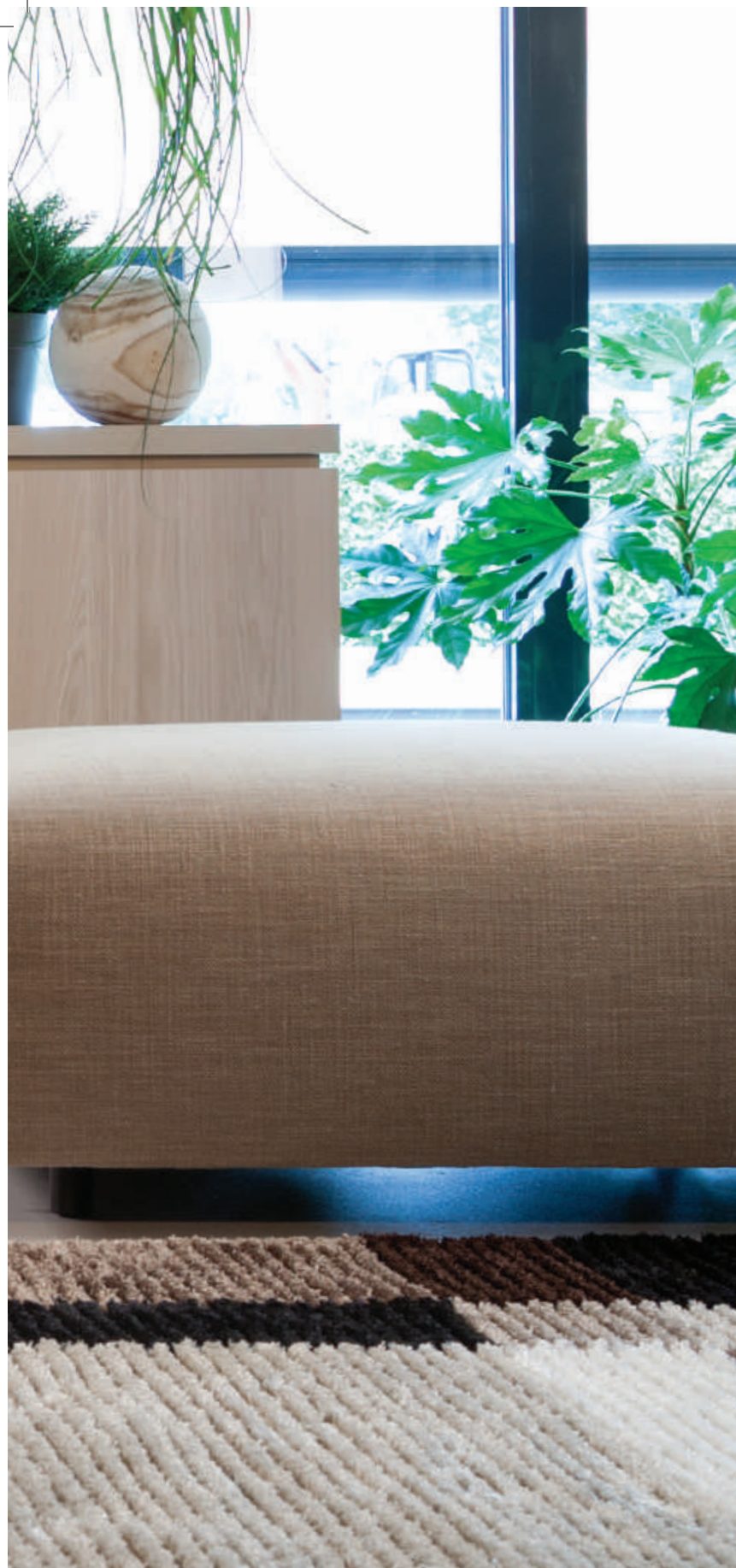

Coming soon:
Kalfire GP75/59F AU

Glass size:

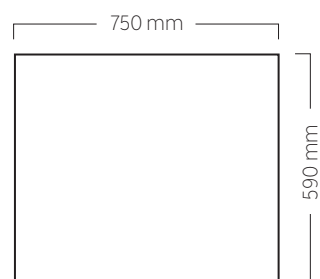

Natural gas



Propane
NZLPG/ULPG

PRODUCT RANGE





KALFIRE GP80/55C



KALFIRE GP85/55S



Coming soon:
Kalfire GP80/55C AU

Glass size:

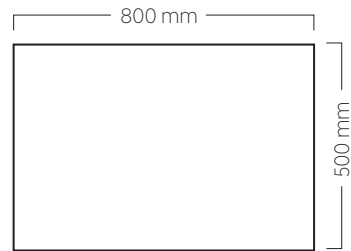

Coming soon:
Kalfire GP85/55S AU

Glass size:



Natural gas



Propane
NZLPG/ULPG

PRODUCT RANGE



KALFIRE
FIREPLACES

DON'T COMPROMISE.

Geloërveldweg 21
5951 DH Belfeld, NL

info@kalfire.com
KALFIRE.COM

01-2020